

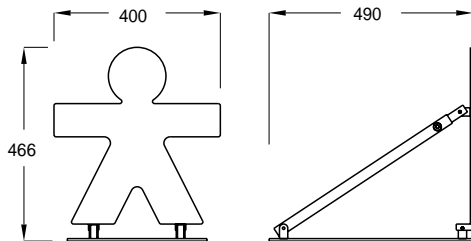

Design: Arch. Federica Fulci

LAPO

COD: 26 5061



Bloccaposto manuale, dotato di predisposizione per chiusura con lucchetto, in laminato piatto di acciaio non legato da 6 mm e supporto intermedio inferiore da 3 mm.

Dimensioni d'ingombro chiuso: manuale 490x400x466h mm
Dimensioni d'ingombro aperto: 920x400x70h mm.
Peso indicativo: 9,5 Kg.

Manual traffic blocker made of a non alloyed rolled steel panel 3 mm thick acting as the intermediate and lower support. It is provided with a hole for safety lock.

Closed overall dimensions: manual 490x400x466h mm.
Opened overall dimensions: 920x400x70h mm.
Indicative weight: 9,5 Kg.



MOON

COD: 26 0800

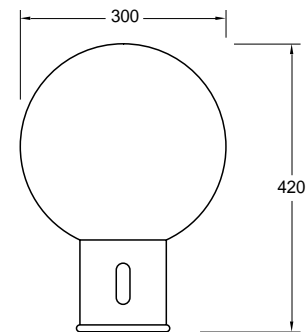

Dissuasore di transito ad inghisare, in fusione di ghisa, sottoposto al processo di sabbiatura e a successiva verniciatura, secondo norme UNI.

Dimensioni d'ingombro:
Ø300x420h mm (fuori terra).
Peso: 21 Kg.

“Moon” model passage bollard, available in the iron casting embedded version. It undergo a process of sand-blasting and polishing in compliance to UNI regulations.

Overall dimensions: Ø300x420h mm.
Indicative weight: 21 Kg.